

ACTA MECHATRONICA

2024 Volume 9

Issue 2

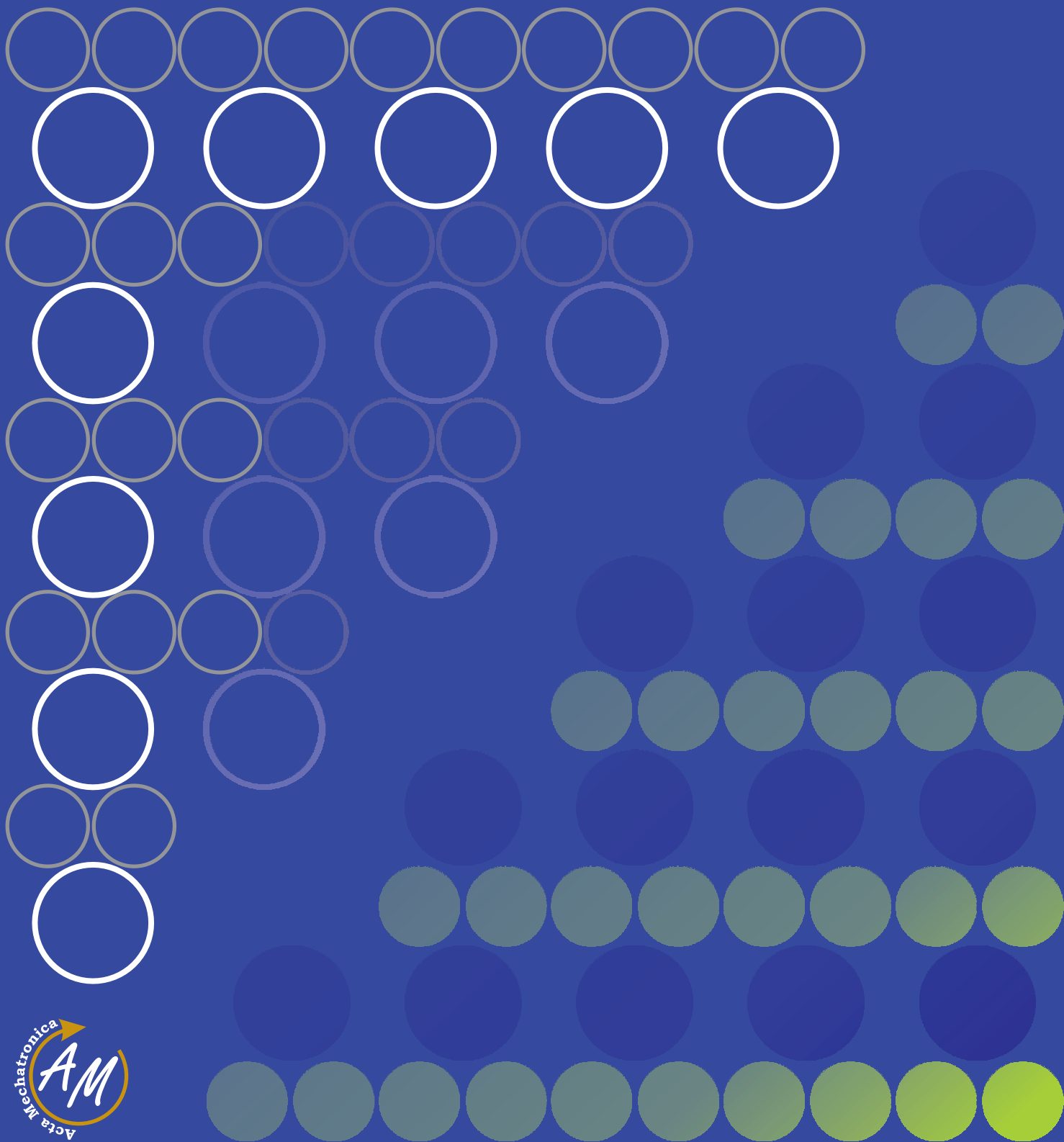

International Scientific Journal about Mechatronics
electronic journal
ISSN 2453-7306



CONTENTS

(JUNE 2024)

(pages 7-14)

Advancements in the design and implementation of auxetic metamaterials

Barbara Schurger, Zuzana Trebunova, Peter Frankovsky

Advancements in the design and implementation of auxetic metamaterials

Barbara Schurger

Department of Applied Mechanics and Mechanical Engineering, Faculty of Mechanical Engineering, Technical University of Kosice, Letná 9, 042 00 Košice, Slovak Republic, EU,
barbara.schurger@tuke.sk (corresponding author)

Zuzana Trebunova

Department of Biomedical Engineering and Measurement, Faculty of Mechanical Engineering, Technical University of Kosice, Letná 9, 042 00 Košice, Slovak Republic, EU,
zuzana.trebunova@student.tuke.sk

Peter Frankovsky

Department of Applied Mechanics and Mechanical Engineering, Faculty of Mechanical Engineering, Technical University of Kosice, Letná 9, 042 00 Košice, Slovak Republic, EU,
peter.frankovsky@tuke.sk

Keywords: auxetic, metamaterial, mechanical properties, additive technology.

Abstract: Auxetic metamaterials, characterized by their negative Poisson's ratio, represent a breakthrough in material science due to their unique mechanical properties. These materials can be engineered to possess characteristics not found in nature, enabling a wide array of applications in fields such as aerospace, automotive, medical devices, and protective equipment. This paper presents design and implementation of auxetic metamaterials, with a focus on their mechanical properties, production techniques, and both numerical and experimental validation. The work aims to highlight the potential of these materials in various industries and propose pathways for future research and development.

1 Introduction

Metamaterials are artificially engineered materials designed to exhibit properties that do not occur naturally. These properties stem from the structure of the material rather than its composition. The term "metamaterial" was first introduced by Roger W. Walters in 1999, and since then, the field has rapidly evolved. Metamaterials are used to manipulate various forms of energy, such as light, sound, and mechanical forces, in ways that were previously impossible [1].

One of the most intriguing classes of metamaterials is **auxetic materials**, which exhibit a negative Poisson's ratio. This means that when an auxetic material is stretched, it expands in the direction perpendicular to the applied force, contrary to the behavior of most conventional materials as seen in Figure 1. This unique property results in enhanced mechanical characteristics, such as superior energy absorption, resistance to indentation, and improved mechanical robustness [2].

Auxetic metamaterials hold great promise in several industries, including aerospace, automotive, biomedical engineering, and construction. These materials are being explored for use in applications that require durability, flexibility, and high mechanical performance. This article provides a comprehensive look at the design and implementation of auxetic metamaterials, emphasizing their mechanical properties and industrial potential [4].

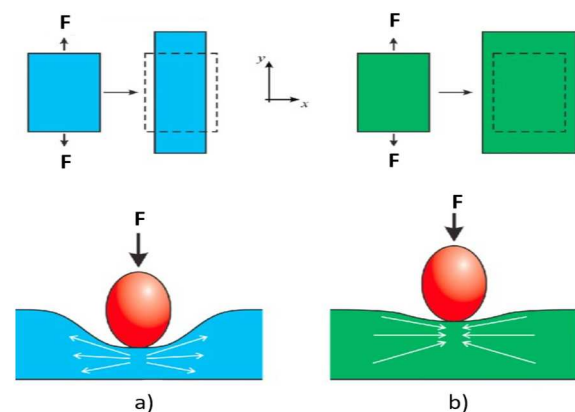

Figure 1 Material behavior under load: (a) conventional material; (b) auxetic material [3]

2 Auxetic structures: design and properties

Auxetic materials are fundamentally different from conventional materials in terms of their mechanical behavior. Their design relies on a special internal structure that allows for expansion under tension rather than contraction, as seen in typical materials. This behavior is quantified by the Poisson's ratio, which for auxetic materials is negative [5,6].

2.1 Mechanical properties of auxetic structure

The primary mechanical feature of auxetic materials is their negative Poisson's ratio, which allows them to expand

laterally when stretched. This property gives rise to several advantages, including:

- 1) **Enhanced energy absorption:** Auxetic materials are particularly effective at absorbing energy (Figure 2), making them ideal for shock absorbers, protective equipment, and impact-resistant components. This property is especially useful in applications where sudden impacts or high forces are encountered [7].

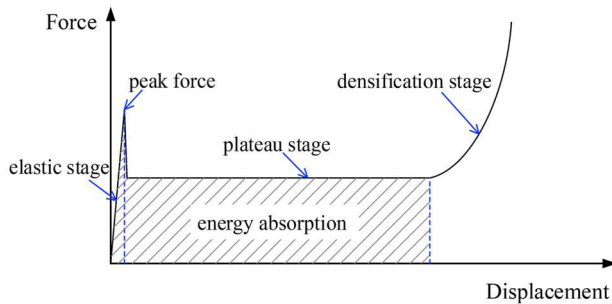

Figure 2 Diagram of force-displacement curve of auxetic energy-absorbing structures [7]

- 2) **Improved indentation resistance:** When force is applied to auxetic materials, their internal structure distributes the load more evenly than conventional materials as seen in Figure 3. This results in improved resistance to indentation, which is beneficial in protective gear, medical implants, and surfaces that are subjected to repeated impacts [8].

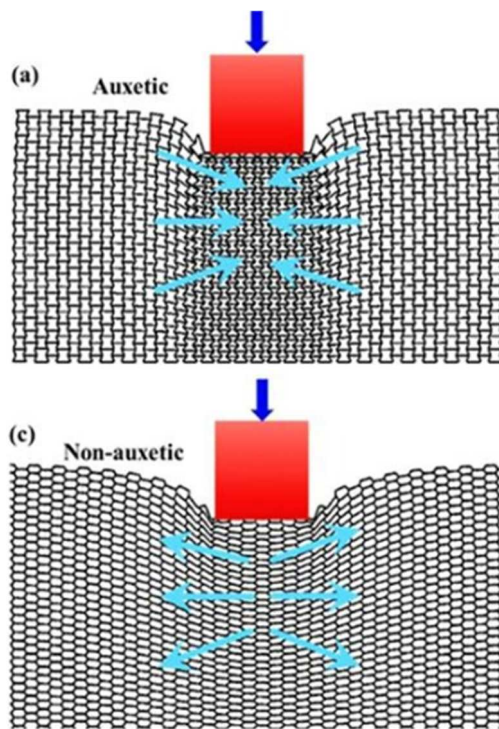

Figure 3 Deformation under indentation by a flat, square-ended punch of a) auxetic structure, b) non-auxetic structure [8]

- 3) **Superior fracture toughness:** Figure 4 shows auxetic structures demonstrating higher resistance to crack propagation compared to traditional materials, which makes them ideal for components exposed to mechanical fatigue and stress [9].

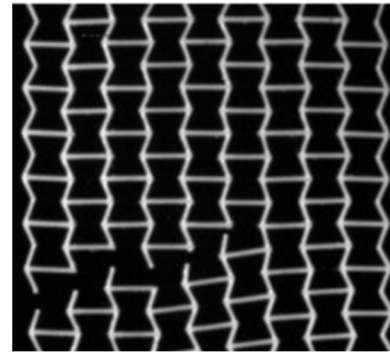

Figure 4 Fracture of re-entrant auxetic structure after tension has been applied [9]

- 4) **Enhanced mechanical strength:** Auxetic materials demonstrate superior mechanical strength due to their internal geometric structure (Figure 5). This strength, combined with their lightweight nature, makes them ideal for use in structural applications where both strength and weight reduction are critical [10].

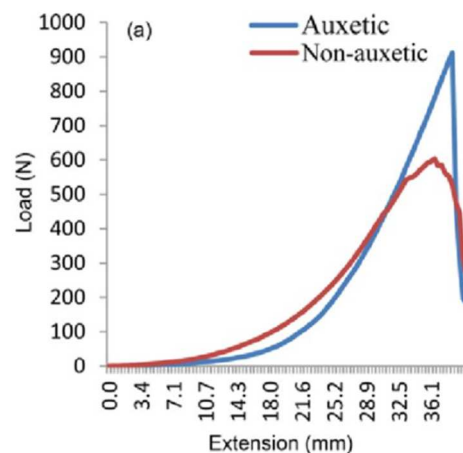

Figure 5 Comparison of tensile strength of auxetic and non-auxetic structure [10]

The mechanical properties of auxetic materials are not solely dependent on the material itself but on the geometry of the auxetic structure. The internal architecture of auxetic structures can be fine-tuned to optimize specific mechanical properties, depending on the intended application [11].

2.2 Numerical and experimental analysis

The design and optimization of auxetic materials rely heavily on numerical simulations. The finite element method (FEM) is a powerful tool used to predict how auxetic materials behave under different loading

conditions. Numerical simulations allow engineers to model the complex behavior of auxetic structures, optimizing their geometry for maximum performance.

Finite Element Method: Through FEM, it is possible to simulate various stress-strain scenarios, determining the material's response to different types of mechanical loads. FEM allows the designer to test multiple design configurations before moving to physical testing, thus saving time and resources. The simulations can also help in predicting failure modes, optimizing material thickness, and evaluating performance under extreme conditions [12].

Experimental Validation: Although numerical simulations provide valuable insights into the mechanical behavior of auxetic materials, experimental validation is essential for confirming the results. Mechanical testing, such as tension, compression, and fatigue tests, are performed on physical prototypes to verify the predicted performance (Figure 6). These tests help validate the material's energy absorption, impact resistance, and other critical properties. Experimental validation also helps identify any discrepancies between theoretical models and real-world behavior, which can arise due to manufacturing imperfections or unexpected environmental conditions [13].



Figure 6 Universal testing machine designed for tensile and compression testing

This combination of simulation and experimentation ensures the reliability of auxetic materials in practical applications.

2.3 Production techniques for auxetic structures

One of the most significant challenges in the field of auxetic materials is the fabrication of structures with complex geometries. Traditional manufacturing techniques are often insufficient for creating the intricate internal architectures required for auxetic behavior. However, additive manufacturing, or 3D printing, has revolutionized the production of auxetic materials, allowing for precise control over their geometry.

Selective laser melting (SLM): SLM is a 3D printing technique that uses a high-powered laser to fuse metal powder into solid structures as seen in Figure 7. This method allows for the production of highly complex auxetic structures with excellent mechanical properties. SLM is particularly useful in industries such as aerospace and automotive, where lightweight yet strong components are needed. By controlling the laser's path, it is possible to create auxetic structures with precise geometric details, ensuring optimal performance under mechanical stress [14].

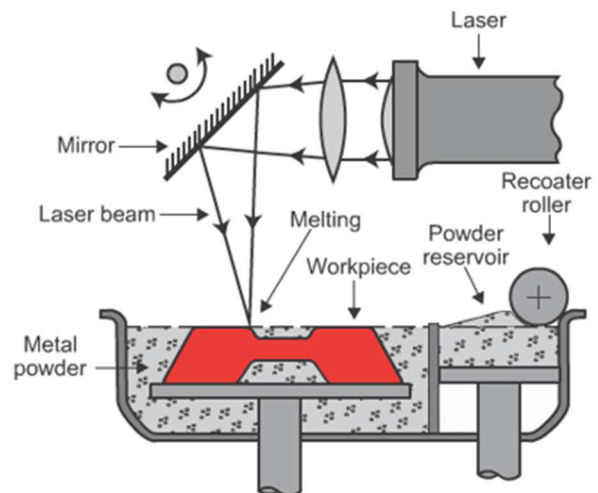

Figure 7 Principle of selective laser melting technique [15]

Stereolithography (SLA): SLA is a 3D printing technique that uses a laser to cure layers of liquid resin into solid parts as seen in Figure 8. SLA is ideal for creating polymer-based auxetic materials, which are often used in medical applications. The high level of precision offered by SLA makes it possible to produce small, intricate auxetic structures, such as stents or scaffolds, that can be used in biomedical applications [16].

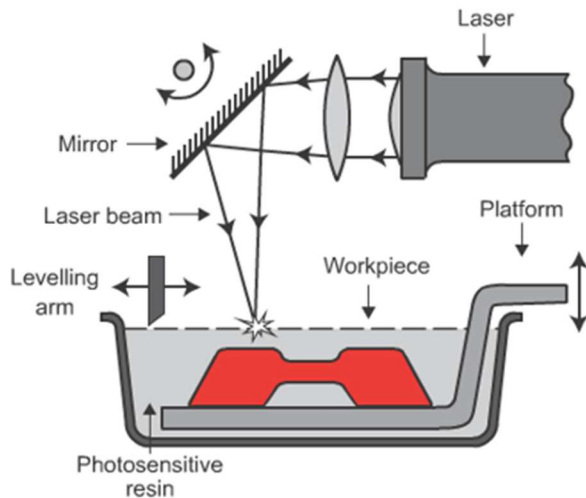

Figure 8 Principle of stereolithography technique [15]

Fused deposition modeling (FDM): FDM is one of the most common forms of 3D printing. It involves the extrusion of molten plastic through a nozzle to build parts layer by layer as seen in Figure 9. Although FDM does not offer the same level of precision as SLM or SLA, it is widely used for prototyping auxetic materials. FDM allows for rapid, low-cost production of auxetic prototypes, making it ideal for research and development purposes [17].

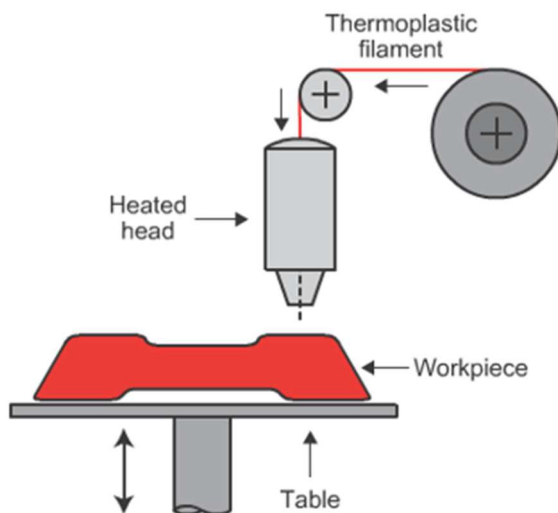

Figure 9 Principle of fused deposition modeling technique [15]

Despite the advancements in 3D printing, there are still challenges associated with manufacturing auxetic materials. The precision required for certain applications, such as medical implants, necessitates tight control over the production process. Variations in layer thickness, material properties, and environmental factors can impact the performance of the final product [18].

Additionally, the choice of material for 3D printing is critical. While metals and polymers are commonly used, researchers are exploring new materials, such as

composites and bio-materials, that can further enhance the performance of auxetic structures [19].

3 Application of auxetic metamaterials

Auxetic metamaterials have a growing range of applications in industries that demand high-performance materials capable of withstanding extreme mechanical forces. Their unique properties have led to their exploration in fields such as medicine, aerospace, automotive, and sports equipment.

3.1 Biomedical devices

In the medical field, auxetic materials are being utilized for various devices, including stents, scaffolds, and prosthetic implants. Auxetic scaffolds are being developed for tissue engineering, where their ability to mimic the mechanical properties of natural tissues supports cellular growth and regeneration. These scaffolds can adapt to the patient's body, promoting faster healing while providing structural support for new tissue formation [20].

Auxetic stents, for instance, can expand uniformly within blood vessels (Figure 10), offering better support and reducing the likelihood of collapse or dislodgement. Their ability to maintain mechanical integrity under dynamic conditions makes them especially valuable in cardiovascular applications [21].

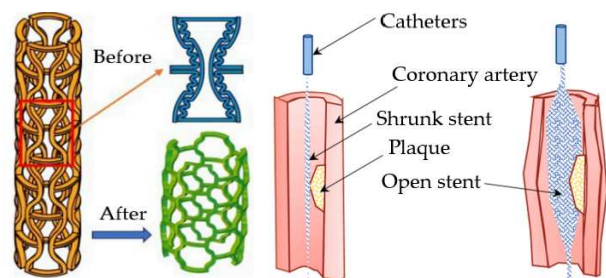

Figure 10 Behavior of auxetic vascular stent before and after activation [21]

Auxetic materials are also used in **spinal intervertebral discs (IVD) implants** (Figure 11), where they can replicate the flexibility and strength of intervertebral discs. Their superior durability under mechanical stress makes them well-suited for long-term implants, reducing the need for surgical revisions [22].

Advancements in the design and implementation of auxetic metamaterials

Barbara Schurger, Zuzana Trebunova, Peter Frankovsky

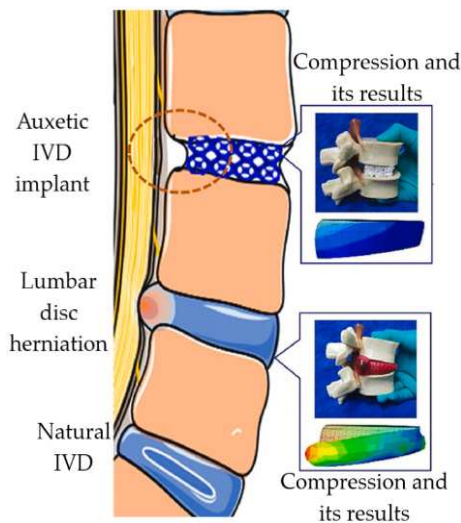

Figure 11 Difference between natural IVD and auxetic IVD implant[22]

3.2 Automotive industry

The automotive industry is particularly interested in auxetic materials for applications where weight reduction and energy absorption are crucial. Auxetic materials are being explored for crash-resistant components (Figure 12), seat cushions, and interior panels. Their ability to absorb impact energy makes them ideal for improving passenger safety in collisions [23].

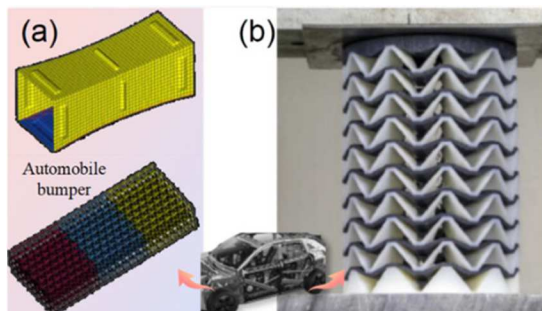

Figure 12 Auxetic structure used as a) automobile bumper, b) jounce bumper[23]

Additionally, auxetic materials can be used in vibration-dampening systems to reduce noise and mechanical wear in vehicle components [24].

3.3 Protective gear and sports equipment

The sports and personal protective equipment industries are adopting auxetic materials for products like helmets, body armor, and sports shoes (Figure 13). Auxetic materials enhanced resistance to impact and deformation provides superior protection against blunt force trauma, making them ideal for use in contact sports and military applications [25].

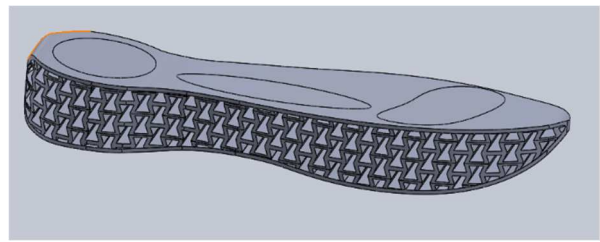

Figure 13 Sports shoe design with auxetic structure for energy absorption [26]

Helmets and protective padding made from auxetic materials can distribute impact forces more evenly across the surface, reducing the risk of localized injuries (Figure 14). The flexibility of auxetic materials also enhances comfort, allowing for better-fitting protective gear that does not compromise movement [27].

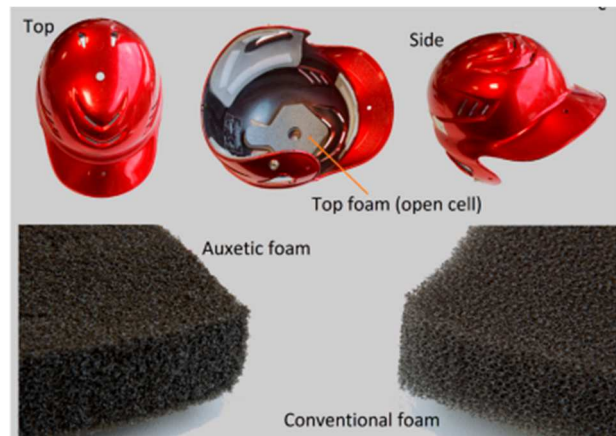

Figure 14 Application of auxetic foam in sports helmet [27]

3.4 Future applications in construction

With their superior load-bearing properties, auxetic materials are being explored for use in building materials and architectural structures. In construction, auxetic materials could improve the safety and durability of buildings by enhancing their ability to absorb seismic shocks (Figure 15) and other forces [28].

Auxetic metamaterials can also contribute to more efficient energy management in buildings. Their ability to control deformation could be harnessed in adaptive structures that change shape in response to environmental conditions, such as temperature or wind pressure, optimizing energy use and reducing overall costs [29].

Advancements in the design and implementation of auxetic metamaterials

Barbara Schurger, Zuzana Trebunova, Peter Frankovsky

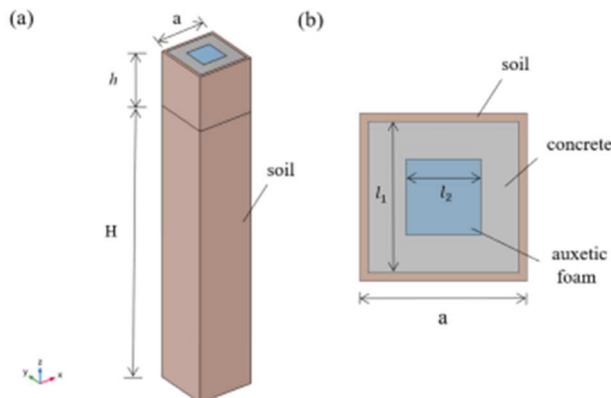

Figure 15 Schematic representation of construction auxetic structure used for seismic shock absorption [28]

4 Future outlook

The potential of auxetic metamaterials extends far beyond their current applications, and ongoing research aims to unlock new possibilities for their use in advanced engineering systems. As manufacturing techniques improve and researchers develop better control over the material properties and geometric configurations, the widespread adoption of auxetic materials is expected to accelerate.

While auxetic materials offer remarkable mechanical properties, challenges remain in scaling up their production for mass-market use. Additive manufacturing must advance to meet the demand for industrial-scale production, and researchers need to explore the use of new materials that can offer even greater mechanical performance under extreme conditions.

The applications of auxetic materials are diverse, ranging from flexible electronics to adaptive building structures. As research continues, auxetic metamaterials will likely revolutionize industries that rely on high-performance materials. Their ability to provide superior mechanical strength, flexibility, and durability makes them invaluable for a future where performance and efficiency are required [30].

5 Conclusions

The growing interest in auxetic metamaterials is largely driven by their potential to meet the increasing demands for lightweight, durable, and energy-efficient materials. In the medical field, for instance, auxetic stents and scaffolds have shown promise in improving patient outcomes by mimicking the mechanical properties of natural tissues. In aerospace and automotive industries, the ability of auxetic materials to withstand extreme forces without compromising structural integrity has the potential to revolutionize vehicle and aircraft design, improving safety and performance while reducing weight. The use of auxetic materials in personal protective equipment, sports gear, and even architectural applications highlights their versatility and far-reaching impact.

As we look to the future, the continued development of auxetic metamaterials is expected to address some of the most pressing challenges in engineering and design. The increasing integration of these materials into various industries will not only lead to better-performing products but will also push the boundaries of what is possible in material science. Innovations in manufacturing processes will be crucial in realizing the full potential of auxetic metamaterials, making it easier to customize and produce them at scale, and at a cost that is accessible for a broader range of applications.

Moreover, the future of auxetic materials lies in their ability to be combined with other cutting-edge technologies. For example, integrating auxetic metamaterials with smart materials could lead to the development of adaptive, self-healing systems that respond dynamically to environmental stimuli. In addition, the exploration of multi-functional metamaterials—those that combine mechanical, electrical, and thermal properties—could open up new possibilities for use in advanced robotics, flexible electronics, and next-generation wearables.

In conclusion, auxetic metamaterials are still in the early stages of their industrial implementation, but their promise is undeniable. The next decade will likely see significant advances in both their design and production, making them an essential component of modern engineering and design. By continuing to refine the fabrication methods and deepen our understanding of their mechanical behavior, auxetic materials could reshape entire industries, providing safer, more efficient, and more resilient solutions to some of the world's toughest engineering challenges. The road ahead is filled with opportunities for innovation, and the role of auxetic metamaterials will only continue to grow as they transition from research labs into everyday applications.

Acknowledgement

The work was supported by the grant project VEGA No. 1/0152/24 and KEGA 039TUKE-4/2024.

References

- [1] GREAVES, G.N., GREER, A.L., ROUXEL, T.: Poisson's ratio and modern materials, *Nature materials*, Vol. 10, No. 11, pp. 823-837, 2011.
- [2] KUMAR, N.S., NAIDU, K.CH.B., BANERJEE, P., BABU, T.A., REDDY, B.V.S.: A review on metamaterials for device applications, *Crystals*, Vol. 11, No. 5, pp. 518-520, 2015. <https://doi.org/10.3390/cryst11050518>
- [3] JI, S., LI, L., MOTRA, H., WUTTKE, F., SUN, S., MICHIBAYASHI, K., SALISBURY, M.H.: Poisson's Ratio and Auxetic Properties of Natural Rocks, *Journal of Geophysical Research: Solid Earth*, Vol. 123, No. 2, pp. 1161-1185, 2018. <https://doi.org/10.1002/2017JB014606>

Advancements in the design and implementation of auxetic metamaterials

Barbara Schurger, Zuzana Trebunova, Peter Frankovsky

- [4] SINGH, G., RAJ, N.I., MARWAHA, A.: A review of metamaterials and its applications, *International journal of engineering trends and technology*, Vol. 19, No. 6, pp. 305-310, 2015.
- [5] CHEN, Z., LIN, Y.-T., SALEHI, H., CHE, Z., ZHU, Y., DING, J., SHENG, B., ZHU, R., JIAO, P.: Advanced fabrication of mechanical metamaterials based on micro or nanoscale technology, *Advanced engineering materials*, Vol. 25, No. 22, 2023.
- [6] CABRAS, L., BRUN, M.: Auxetic two-dimensional lattices with Poisson's ratio arbitrarily close to -1, *Proceedings of the royal society*, Vol. 470, pp. 1-23, 2023. <http://dx.doi.org/10.1098/rspa.2014.0538>
- [7] ZHANG, J., LU, G., YOU, Z.: Large deformation and energy absorption of additively manufactured auxetic materials and structures: A review, *Composites Part B: Engineering*, Vol. 201, No. November, 108340, 2020. <https://doi.org/10.1016/j.compositesb.2020.108340>
- [8] LI, Z., WANG, K.F., WANG, B.L.: Indentation resistance of brittle auxetic structures: Combining discrete representation and continuum model, *Engineering Fracture Mechanics*, Vol. 252, No. July, 107824, 2021. <https://doi.org/10.1016/j.engfracmech.2021.107824>
- [9] HANIFPOUR, M., PETERSEN, C., ALAVA, M., ZAPPERI, S.: Mechanics of disordered auxetic metamaterials, *The European Physical Journal B*, Vol. 91, No. 11, 2018. <https://doi.org/10.1140/epjb/e2018-90073-1>
- [10] ALI, M., ZEESHAN, M., QADIR, M.B., RIAZ, R., AHMAD, S., NAWAB, Y., ANJUM, A.S.: Development and Mechanical Characterization of Weave Design Based 2D Woven Auxetic Fabrics for Protective Textiles, *Fibers and Polymers*, Vol. 19, No. 11, pp. 2431-2438, 2018.
- [11] SCHURGER, B., FRANKOVSKY, P., JANIGOVA, S., BOCKO, J., KOLODZIEJ, A.: Mechanical metamaterials: properties and classification, *Acta Mechatronica*, Vol. 8, No. 3, pp. 29-35, 2023. <https://doi.org/10.22306/am.v8i3.98>
- [12] TREBUŇA, F., ŠIMČÁK, F.: *Odolnosť prvkov mechanických sústav*, Košice, TUKE, 2005. (Original in Slovak)
- [13] TREBUŇA, F., ŠIMČÁK, F., JURICA, V.: *Pružnosť a pevnosť I.*, Košice, TUKE, 2000. (Original in Slovak)
- [14] CIOBOTA, N.-D., GHEORGHE, G.: 3D complex structures through fused deposition modeling as a rapid prototyping technology designed for replacing anatomic parts of human body, *Scientific bulletin of valahia university - materials and mechanics*, Vol. 16, No. 15, pp. 30-33, 2018.
- [15] TELFER, S., PALLARI, J., MUNGUIA, J., DALGARNO, K., MCGEOUGH, M., WOODBURN, J.: Embracing additive manufacture: Implications for foot and ankle orthosis design, *BMC Musculoskeletal Disorders*, Vol. 13, pp. 1-9, 2012. <https://doi.org/10.1186/1471-2474-13-84>
- [16] RUDNIK, M.: Influence of size on the compressive properties of cellular structures manufactured by additive technologies, *Mechanik*, Vol. 4, pp. 1-10, 2024.
- [17] MADHU, N.R., ERFANI, H., JADOUN, S., AMIR, M., THIAGARAJAN, Y., PAL, N., CHAUHAN, S.: Fused deposition modelling approach using 3D printing and recycled industrial materials for a sustainable environment: a review, *The International Journal of Advanced Manufacturing Technology*, Vol. 122, pp. 2125-2138, 2022. <https://doi.org/10.1007/s00170-022-10048-y>
- [18] AHMAD, N.N., WONG, Y.H., GHAZALI, N.N.N.: A systematic review of fused deposition modeling process parameters, *Soft science*, Vol. 2, pp. 3-11, 2022.
- [19] TRIYONO, J., SUKANTO, H., SAPUTRA, R.M., SMARADHANA, D.F.: The effect of nozzle hole diameter of 3D printing on porosity and tensile strength using polyactic acid material, *Open engineering*, Vol. 10, pp. 762-768, 2020.
- [20] ROSE, S., SIU, D., ZHU, J., ROUFAIL, R. Auxetics in Biomedical Applications: A Review, *Journal of Minerals and Materials Characterization and Engineering*, Vol. 11, No. 2, pp. 27-35, 2023.
- [21] EBRAHIMI, M.S., NORUZI, M., HAMZEHEI, R., ETEMADI, E., HASHEMI, R.: Revolutionary auxetic intravascular medical stents for angioplasty applications, *Materials & Design*, Vol. 235, pp. 1-17, 2023.
- [22] JIANG, Y., SHI, K., ZHOU, L., HE, M., ZHU, C., WANG, J., LI, J., LI, Y., LIU, L., SUN, D., FENG, G., YI, Y., ZHANG, L.: 3D-printed auxetic-structured intervertebral disc implant for potential treatment of lumbar herniated disc, *Bioactive Materials*, Vol. 20, pp.528-538, 2023.
- [23] LIU, Y., ZHAO, CH., XU, CH., REN, J., ZHONG, J.: Auxetic meta-materials and their engineering applications: a review, *Engineering Research Express*, Vol. 5, pp. 1-13, 2023. <https://doi.org/10.1088/2631-8695/ad0eb1>
- [24] GUPTA, V., CHATTORAJ, A., BANARJEE, A., BHATTACHARYA, B.: Wave propagation in auxetic mechanical metamaterial: Bloch formalism for various boundary conditions, *Active and Passive Smart Structures and Integrated Systems XIII*, Vol. 10967, 2019. <https://doi.org/10.1117/12.2514266>
- [25] SANAMI, M., RAVIRALA, N., ALDERSON, K., ALDERSON, A.: Auxetic Materials for Sports Applications, *Procedia Engineering*, Vol. 72, pp. 453-458, 2014. <https://doi.org/10.1016/j.proeng.2014.06.079>
- [26] SĂRĂNDAN, S., NEGRU, R., MARSAVINA, L., SERBAN, D.-A.: Cellular materials used in athletic footwear applications: Experimental, analytical and

Advancements in the design and implementation of auxetic metamaterials

Barbara Schurger, Zuzana Trebunova, Peter Frankovsky

- numerical investigations, *Materials Today: Proceedings*, Vol. 45, No. 5, pp. 4310-4314, 2021.
- [27] FOSTER, L., PEKETI, P., ALLEN, T.: Application of auxetic foam in sports helmets, *Applied Sciences*, Vol. 8, No. 3, pp. 354-360, 2018.
<https://doi.org/10.3390/app8030354>
- [28] LUO, Y.M., HE, C., TAO, Z.: A surface-wave seismic metamaterial filled with auxetic foam, *International Journal of Mechanical Sciences*, Vol. 262, No. 6, pp. 256-266, 2024.
- [29] FERGUSON, W.J.G., KUANG, Y., EVANS, K.E., SMITH, CH.W., ZHU, M.: Auxetic structure for increased power output of strain vibration energy harvester, *Sensors and Actuators A: Physical*, Vol. 282, pp. 90-96, 2018.
- [30] BALAN, M., MERTENS, J., BAHUBALENDRUNI, R.: Auxetic mechanical metamaterials and their futuristic developments: A state-of-art review, *Materials Today Communications*, Vol. 34, 2023.
<https://doi.org/10.1016/j.mtcomm.2022.105285>

Review process

Single-blind peer review process.

JOURNAL STATEMENT

Journal name:	Acta Mechatronica
Abbreviated key title:	Acta Mechatron
Journal title initials:	AM
Journal doi:	10.22306/am
ISSN:	2453-7306
Start year:	2016
The first publishing:	March 2016
Issue publishing:	Quarterly
Publishing form:	On-line electronic publishing
Availability of articles:	Open Access Journal
Journal license:	CC BY-NC
Publication ethics:	COPE, ELSEVIER Publishing Ethics
Plagiarism check:	Worldwide originality control system
Peer review process:	Single-blind review at least two reviewers
Language:	English
Journal e-mail:	info@actamechatronica.eu

The journal focuses mainly on original, interesting, new and quality, theoretical, practical and application-oriented contributions to the scientific fields and research as well as to pedagogy and training in mechatronics.

Acta Mechatronica journal supports the San Francisco Declaration on Research Assessment (DORA). The primary directives include open access, reuse of outputs, diversity among authors and reviewers, peer review, description of provided services and related publishing charges.

Publisher:	4S go, s.r.o.
Address:	Semsa 24, 044 21 Semsa, Slovak Republic, EU
Phone:	+421 948 366 110
Publisher e-mail:	info@4sgo.eu

Responsibility for the content of a manuscript rests upon the authors and not upon the editors or the publisher.